

## Step-by-step installation instructions:

### Unexposed side:

1. Insert PEF rod 10mm (nominal) into the annular space.
2. Apply 10mm (nominal) AGNI-Seal on the PEF rod into the annular space, finishing flush with the top of the slab.

### Exposed side:

1. Insert PEF rod 10mm (nominal) into the annular space.
2. Apply 10mm (nominal) AGNI-Seal on the PEF rod into the annular space, finishing flush with the bottom of the slab.
3. Wrap AGNI-Collar around the pipe and secure using screws.



### Technical Information

System ID	AP-220
Substrate	<ul style="list-style-type: none"> <li>• Min. 120mm concrete floor/ceiling</li> </ul>
Service range	From DN40mm up to DN150mm PVC-U pipes
Annular gap	DN40mm - 0.0-10mm DN50mm - 0.0-4.7mm DN65mm - 0.0-8.4mm DN80mm - 0.0-11.4mm DN100mm - 0.0-24.5mm DN150mm - 0.0-12.9mm
AGNI-Products	AGNI-Collar, AGNI-Seal
Protection installation	Asymmetrical

### Compliance Information

Standards	AS1530.4-2014, AS4072.1-2005
FRR/FRL	-/120/120
Reference	PF25037



8 Clare St Bayswater  
 VIC 3153, AUSTRALIA  
 +61 (03) 7045 4242  
 info@agnitek.com.au  
 www.agnitek.com.au

#### Disclaimer

Agnitek reserves the right to modify product specifications without prior notice due to its ongoing research, development & certification programme. The information in this document is provided in good faith and is intended for guidance purposes only. Any accompanying drawings are solely for illustrative purposes. Since Agnitek cannot oversee installation methods or ensure site conditions, no warranties, expressed or implied, are intended regarding the products' actual performance. We do not accept liability for any loss, damage, or injury from using this information. Please take a look at the test reports displayed on a relevant AGNI-System webpage for all compliance specifics.

Date	12.05.2025
------	------------

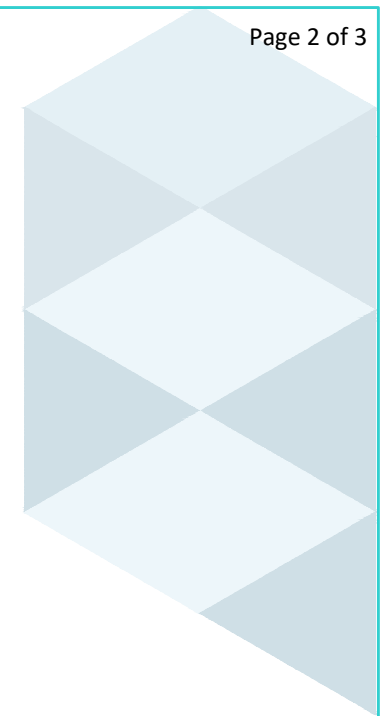
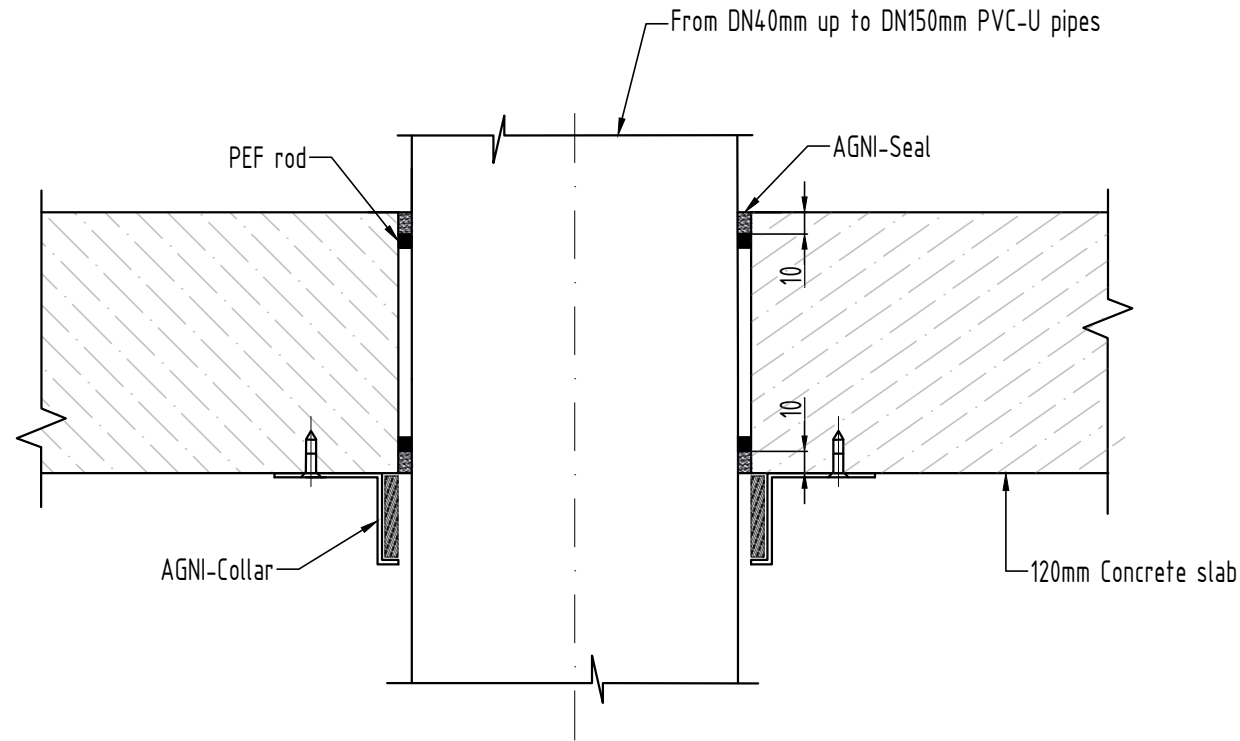

Technical Information

System ID	AP-220
Substrate	<ul style="list-style-type: none"> <li>Min. 120mm concrete floor/ceiling</li> </ul>
Service range	From DN40mm up to DN150mm PVC-U pipes
Annular gap	DN40mm - 0.0-10mm DN50mm - 0.0-4.7mm DN65mm - 0.0-8.4mm DN80mm - 0.0-11.4mm DN100mm - 0.0-24.5mm DN150mm - 0.0-12.9mm
AGNI-Products	AGNI-Collar, AGNI-Seal
Protection installation	Asymmetrical

Compliance Information

Standards	AS1530.4-2014, AS4072.1-2005
FRR/FRL	-/120/120
Reference	PF25037



8 Clare St Bayswater  
 VIC 3153, AUSTRALIA  
 +61 (03) 7045 4242  
 info@agnitek.com.au  
 www.agnitek.com.au

**Disclaimer**  
 Agnitek reserves the right to modify product specifications without prior notice due to its ongoing research, development & certification programme. The information in this document is provided in good faith and is intended for guidance purposes only. Any accompanying drawings are solely for illustrative purposes. Since Agnitek cannot oversee installation methods or ensure site conditions, no warranties, expressed or implied, are intended regarding the products' actual performance. We do not accept liability for any loss, damage, or injury from using this information. Please take a look at the test reports displayed on a relevant AGNI-System webpage for all compliance specifics.

Date	12.05.2025
------	------------