

## Step-by-step installation instructions:

1. Apply 10mm (nominal) AGNI-Seal into the annular space and finish flush with the lining.
2. Wrap AGNI-Collar around the pipe and secure in the fixing points using the screws.



### Technical Information

System ID	AP-219
Substrate	<ul style="list-style-type: none"> <li>• Min. 64mm timber or steel stud wall with a minimum of one layer of 13mm (or greater) FR plasterboard on each side, with or without insulation.</li> <li>• Min. 90mm concrete wall</li> </ul>
Service range	From DN40mm up to DN110mm HDPE pipes
Annular gap	DN40mm - 0.0-12.7mm DN90mm - 0.0-11.8mm DN110mm - 6.3-17.1mm
AGNI-Products	AGNI-Collar, AGNI-Seal
Protection installation	From both sides of the wall

### Compliance Information

Standards	AS1530.4-2014, AS4072.1-2005
FRR/FRL	-/60/60
Reference	PF25036, PF25004



8 Clare St Bayswater  
 VIC 3153, AUSTRALIA  
 +61 (03) 7045 4242  
 info@agnitek.com.au  
 www.agnitek.com.au

Date 12.05.2025

#### Disclaimer

Agnitek reserves the right to modify product specifications without prior notice due to its ongoing research, development & certification programme. The information in this document is provided in good faith and is intended for guidance purposes only. Any accompanying drawings are solely for illustrative purposes. Since Agnitek cannot oversee installation methods or ensure site conditions, no warranties, expressed or implied, are intended regarding the products' actual performance. We do not accept liability for any loss, damage, or injury from using this information. Please take a look at the test reports displayed on a relevant AGNI-System webpage for all compliance specifics.

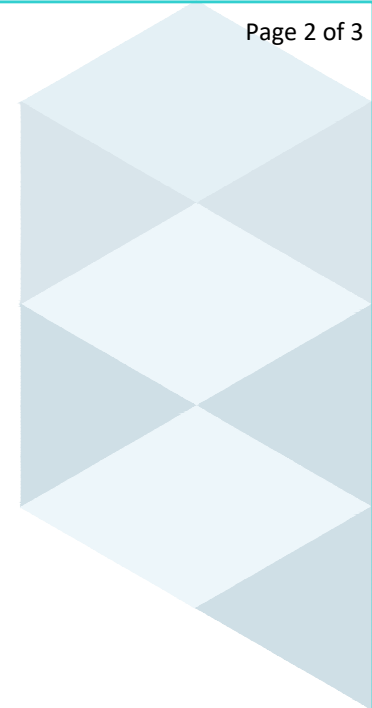
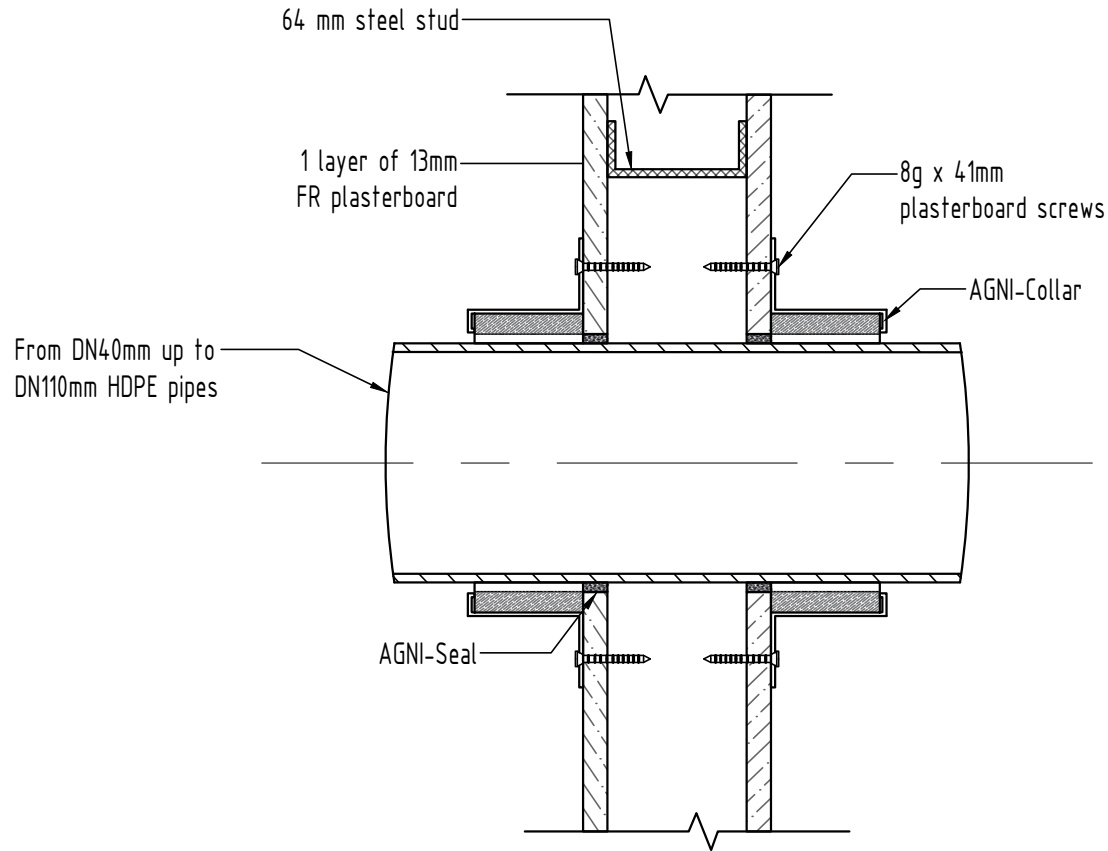

Technical Information

System ID	AP-219
Substrate	<ul style="list-style-type: none"> <li>• Min. 64mm timber or steel stud wall with a minimum of one layer of 13mm (or greater) FR plasterboard on each side, with or without insulation.</li> <li>• Min. 90mm concrete wall</li> </ul>
Service range	From DN40mm up to DN110mm HDPE pipes
Annular gap	DN40mm - 0.0-12.7mm DN90mm - 0.0-11.8mm DN110mm - 6.3-17.1mm
AGNI-Products	AGNI-Collar, AGNI-Seal
Protection installation	From both sides of the wall

Compliance Information

Standards	AS1530.4-2014, AS4072.1-2005
FRR/FRL	-/60/60
Reference	PF25036, PF25004



8 Clare St Bayswater  
 VIC 3153, AUSTRALIA  
 +61 (03) 7045 4242  
 info@agnitek.com.au  
 www.agnitek.com.au

Date 12.05.2025

**Disclaimer**  
 Agnitek reserves the right to modify product specifications without prior notice due to its ongoing research, development & certification programme. The information in this document is provided in good faith and is intended for guidance purposes only. Any accompanying drawings are solely for illustrative purposes. Since Agnitek cannot oversee installation methods or ensure site conditions, no warranties, expressed or implied, are intended regarding the products' actual performance. We do not accept liability for any loss, damage, or injury from using this information. Please take a look at the test reports displayed on a relevant AGNI-System webpage for all compliance specifics.