

# AGNI-System №AP-158

## Step-by-step installation instructions:

1. Ensure the aperture is free from dust and debris.
2. Push 20mm nominal thick AGNI-Board into the annular gap around the pipe.
3. Cut 110mm wide AGNI-Sleeve to fit one revolution of the aperture.
4. Cut AGNI-Sleeve to make two 40mm (high) x 10mm (wide) fixing tabs placed 300mm centres or 50mm from the edges of the AGNI-Sleeve.
5. Bend over the AGNI-Sleeve tabs and push the AGNI-Sleeve into the annular gap.
6. Secure the AGNI-Sleeve using masonry screws.



### Technical Information

System ID	AP-158
Substrate	Min. 130mm thick concrete horizontal floor (60mm profiled decking with 70mm topping)
Service range	From DN32mm up to 100mm PVC-U pipes
Annular gap	4.6 - 12.7mm
AGNI-Products	AGNI-Sleeve, AGNI-Board
Protection installation	Asymmetrical (installed from below the floor/ceiling)
Passing through the 70mm topping	Yes
Passing through the rib	Yes (Yes & No for DN100mm pipe only)

### Compliance Information

Standards	AS1530.4-2014, AS4072.1-2005
FRR/FRL	-/60/60
Reference	PF24123



8 Clare St Bayswater  
VIC 3153, AUSTRALIA  
+61 (03) 7045 4242  
info@agnitek.com.au  
www.agnitek.com.au

Date 10.01.2025

#### Disclaimer

Agnitek reserves the right to modify product specifications without prior notice due to its ongoing research, development & certification programme. The information in this document is provided in good faith and is intended for guidance purposes only. Any accompanying drawings are solely for illustrative purposes. Since Agnitek cannot oversee installation methods or ensure site conditions, no warranties, expressed or implied, are intended regarding the products' actual performance. We do not accept liability for any loss, damage, or injury from using this information. Please take a look at the test reports displayed on a relevant AGNI-System webpage for all compliance specifics.

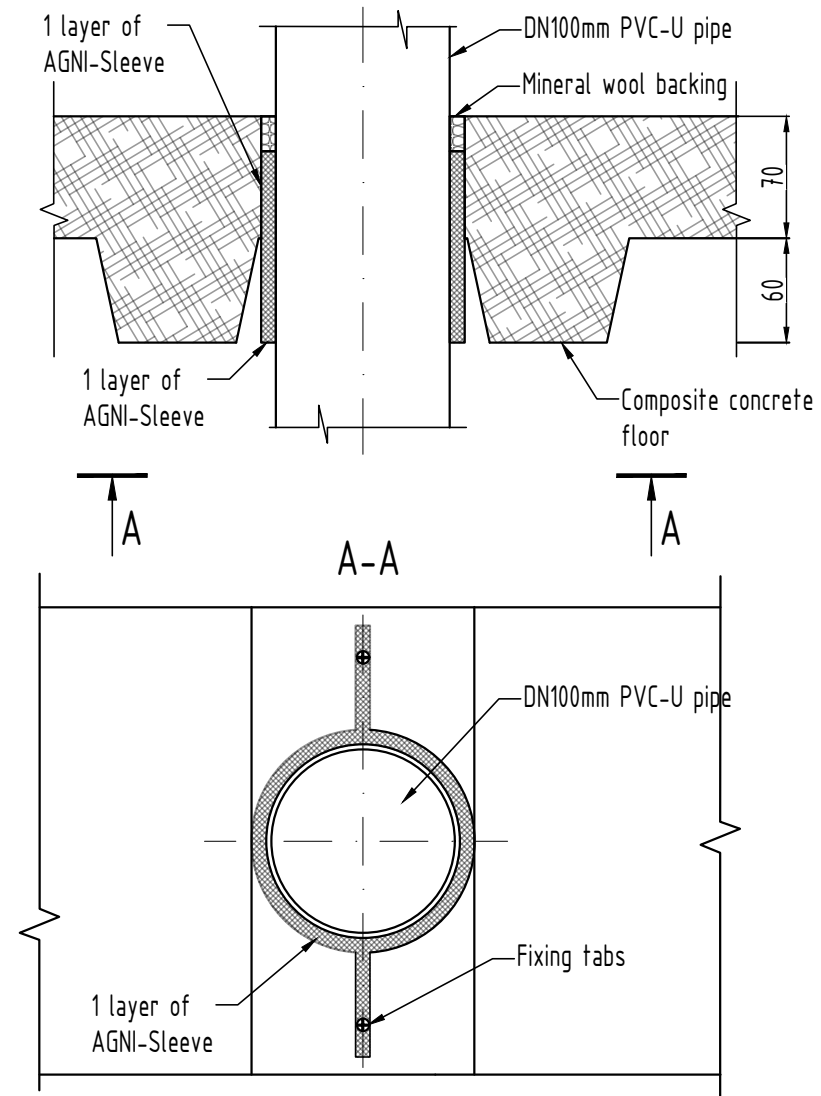
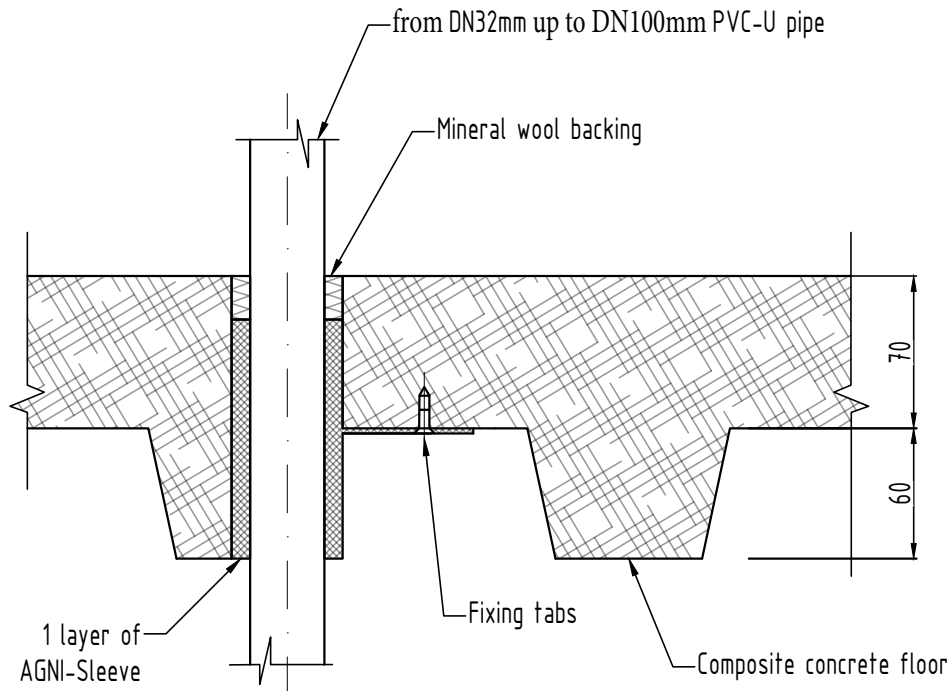

### Technical Information

System ID	AP-158
Substrate	Min. 130mm thick concrete horizontal floor (60mm profiled decking with 70mm topping)
Service range	From DN32mm up to 100mm PVC-U pipes
Annular gap	4.6 - 12.7mm
AGNI-Products	AGNI-Sleeve, AGNI-Board
Protection installation	Asymmetrical (installed from below the floor/ceiling)
Passing through the 70mm topping	Yes
Passing through the rib	Yes (Yes & No for DN100mm pipe only)

### Compliance Information

Standards	AS1530.4-2014, AS4072.1-2005
FRR/FRL	-/60/60
Reference	PF24123



**Agnitek**  
FIRE RATED TECHNOLOGY

8 Clare St Bayswater  
VIC 3153, AUSTRALIA  
+61 (03) 7045 4242  
info@agnitek.com.au  
www.agnitek.com.au

#### Disclaimer

Agnitek reserves the right to modify product specifications without prior notice due to its ongoing research, development & certification programme. The information in this document is provided in good faith and is intended for guidance purposes only. Any accompanying drawings are solely for illustrative purposes. Since Agnitek cannot oversee installation methods or ensure site conditions, no warranties, expressed or implied, are intended regarding the products' actual performance. We do not accept liability for any loss, damage, or injury from using this information. Please take a look at the test reports displayed on a relevant AGNI-System webpage for all compliance specifics.

Date	12.12.2024
------	------------