

AGNI-System №AP-096

Step-by-step installation instructions:

1. Ensure the aperture is free from dust and debris.
2. Remove the base fabric of AGNI-Sleeve before installation.
3. Wrap 120mm wide AGNI-Sleeve around the service, where 10mm of AGNI-Sleeve extends beyond the CLT wall on both sides.
4. Seal all joints with a nominal 5mm bead of AGNI-Seal on both sides of the wall.



Technical Information

System ID	AP-096
Substrate	Min. 100m CLT wall
Service range	DN 16mm - 25mm PEX pipe
Annular gap	4.35mm - 6.65mm
AGNI-Products	AGNI-Seal, AGNI-Sleeve
Protection installation	Both sides of the wall

Compliance Information

Standards	AS1530.4-2014, AS4072.1-2005
FRR/FRL	-/60/60
Reference	PF24086



8 Clare St Bayswater
VIC 3153, AUSTRALIA
+61 (03) 7045 4242
info@agnitek.com.au
www.agnitek.com.au

Date 30.08.2024

Disclaimer

Agnitek reserves the right to modify product specifications without prior notice due to its ongoing research, development & certification programme. The information in this document is provided in good faith and is intended for guidance purposes only. Any accompanying drawings are solely for illustrative purposes. Since Agnitek cannot oversee installation methods or ensure site conditions, no warranties, expressed or implied, are intended regarding the products' actual performance. We do not accept liability for

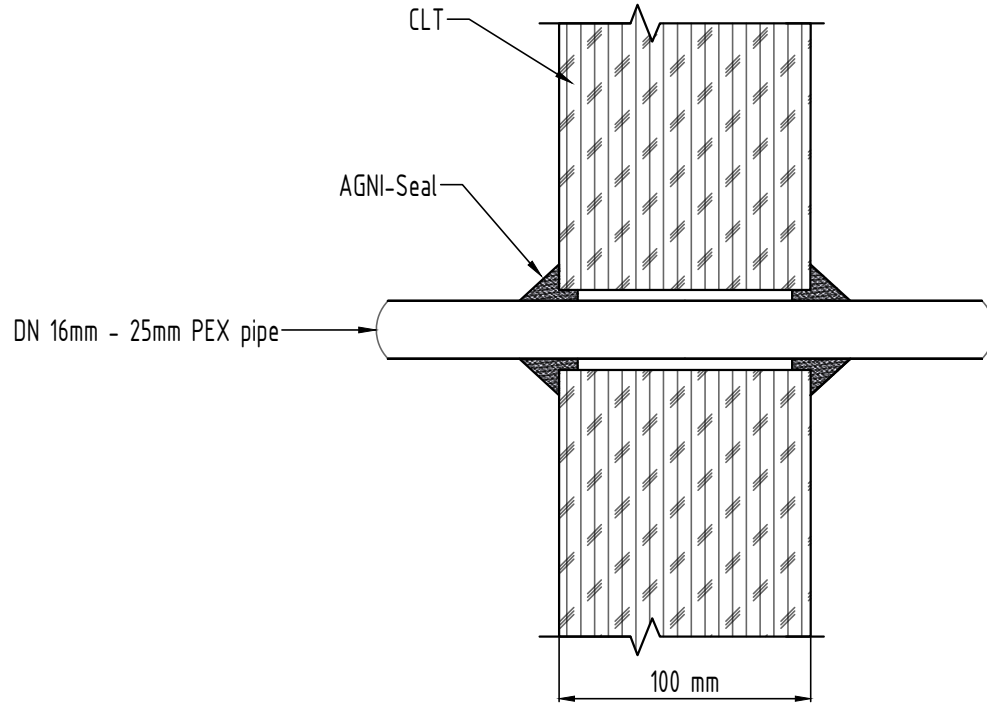

Technical Information

System ID	AP-096
Substrate	Min. 100m CLT wall
Service range	DN 16mm - 25mm PEX pipe
Annular gap	4.35mm - 6.65mm
AGNI-Products	AGNI-Seal, AGNI-Sleeve
Protection installation	Both sides of the wall

Compliance Information

Standards	AS1530.4-2014, AS4072.1-2005
FRR/FRL	-/60/60
Reference	PF24086



Agnitek[®]
FIRE RATED TECHNOLOGY

8 Clare St Bayswater
VIC 3153, AUSTRALIA
+61 (03) 7045 4242
info@agnitek.com.au
www.agnitek.com.au

Date	30.08.2024
------	------------

Disclaimer
Agnitek reserves the right to modify product specifications without prior notice due to its ongoing research, development & certification programme. The information in this document is provided in good faith and is intended for guidance purposes only. Any accompanying drawings are solely for illustrative purposes. Since Agnitek cannot oversee installation methods or ensure site conditions, no warranties, expressed or implied, are intended regarding the products' actual performance. We do not accept liability for